



## HAWAII - HWR-S

HWR: HAWAII REMOTE COMPRESSOR  
S: SINGLE ISLAND

### COMMERCIAL LINE — DISPLAY CASES



ISLAND  
CHILLER/FREEZER

#### Features & Benefits:

- Sleek Full View glass walls (370mm) around the Single Deck Display Case provide great product visibility.
- The Single Island gives you the flexibility of having an Island Display without compromising floor space.
- Uniformed air circulation eliminates frosting blockage issues.
- Durable Galvanneal Steel Structure with powder coating for additional protection. (Choose any RAL color. Outside and inside can be coated different color at no additional cost.)
- Different temperature ranges can be set according to application: +2°C to -2° C or -18°C to -22°C.
- Built-in Anti-Sweat Heaters prevent condensation.
- Rust protection and preservative treatment conducted for all components.
- Easy Maintenance; reduce labor time and costs with easy access under the Display Case.
- Attractive Bumper system for protection.



COVER  
OPTIONS



CHOICE OF REAL COLOR



**Standard Options:**

- Available lengths: **18** (1875mm), **22** (2200mm), **25** (2500mm), **37** (3750mm) can be joined together to meet layout requirements.
- Case Cover: Open with incorporated retractable Night Curtain or Closed with Sliding Glass Doors.
- End Wall Panels available: Polyurethane, Polyurethane w/Full View Thermo-pane Glass.
- Defrost: Electric.
- Thermostatic Expansion Valve with Balanced Port for better control of superheat. (Danfoss or Sporlan brand)
- Fan Motor: EBM brand, AC type (Standard Efficiency).
- High efficiency coil design with corrugated aluminum fins and variable spacing augment efficiency and allow for more frost build-up before Defrosting becomes necessary.
- Controllers: Carel brand standard.

ATTRACTIVE BUMPER SYSTEM



**Additional Options:**

- "ASHSC" Anti-Sweat Heater Smart Control: automatically adjusts the thermo-pane glass temperature according to humidity and temperature inside the store which reduces energy costs.\*
- Bin Dividers: Powder Coated Steel Wire or Organic Glass.
- Defrost: Hot Gas.
- **EV2** electronic Expansion Valve saves up to 10% energy (Carel brand).\*
- Fan Motor: EBM brand, EC type (High Efficiency) **GreenTech** technology can reduce the fan power consumption up to 70%.
- Controllers: Various Carel or other brand options available.

*\*For specific control type. Contact us for more details. Refer to our technical guide for specific information.*

COMBINE FOR DESIRED LENGTH





**END-CAP  
FOR HAWAII D (DOUBLE ISLAND)**

1 Cover – 0: Open w/Night Curtain

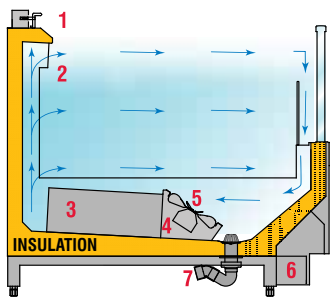

1 Cover – G: Closed w/Sliding Glass Door

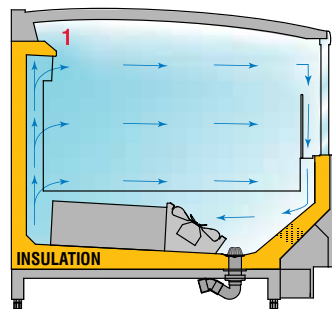

- 1. Cover Option
- 2. Air Curtain
- 3. Coil
- 4. Plenum
- 5. Fan Motor
- 6. Electrical Box
- 7. Drain

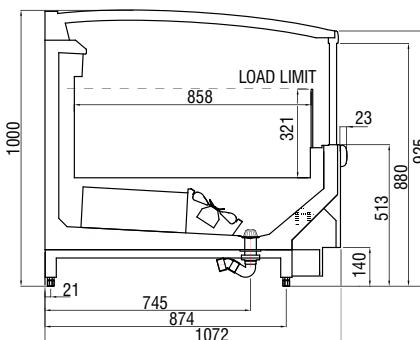
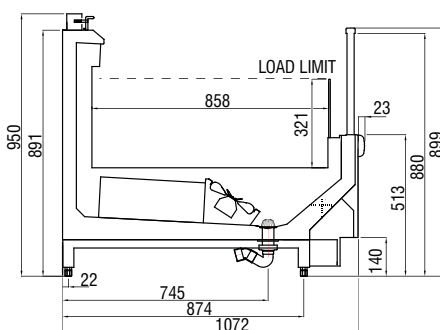

CAPACITIES ACCORDING TO AHRI 1200 STANDARD GUIDELINES		
	DA: Display Area (m <sup>2</sup> )	RV: Refrigerated Volume (m <sup>3</sup> )
18 (1875mm)	1.90	0.514
22 (2200mm)	2.23	0.603
25 (2500mm)	2.54	0.685
37 (3750mm)	3.81	1.028
Ae	0.16	n/a

TDA: (Total Display Area) = DA + Ae  
Ae = Projected area from End Wall Panel w/Glass

**OPTIONAL BIN DIVIDERS**



**Dividers:**  
Powder Coated Steel Wire or Organic Glass

The table below shows the standard quantity when ordering optional Dividers. Additional Dividers may be ordered separately.

**A – Out:** Wall Retainer - Wire or Glass. (For End-Cap or End Wall Panel with glass.)  
**B – In:** Dividers - Wire Only.

DIVIDER QUANTITIES				
18 (1875mm)	22 (2500mm)	25 (2500mm)	37 (3750mm)	End-Cap
2	3	3	5	4 (2 Out + 2 In)

**NOMENCLATURE: ISLAND (SINGLE BIN)**

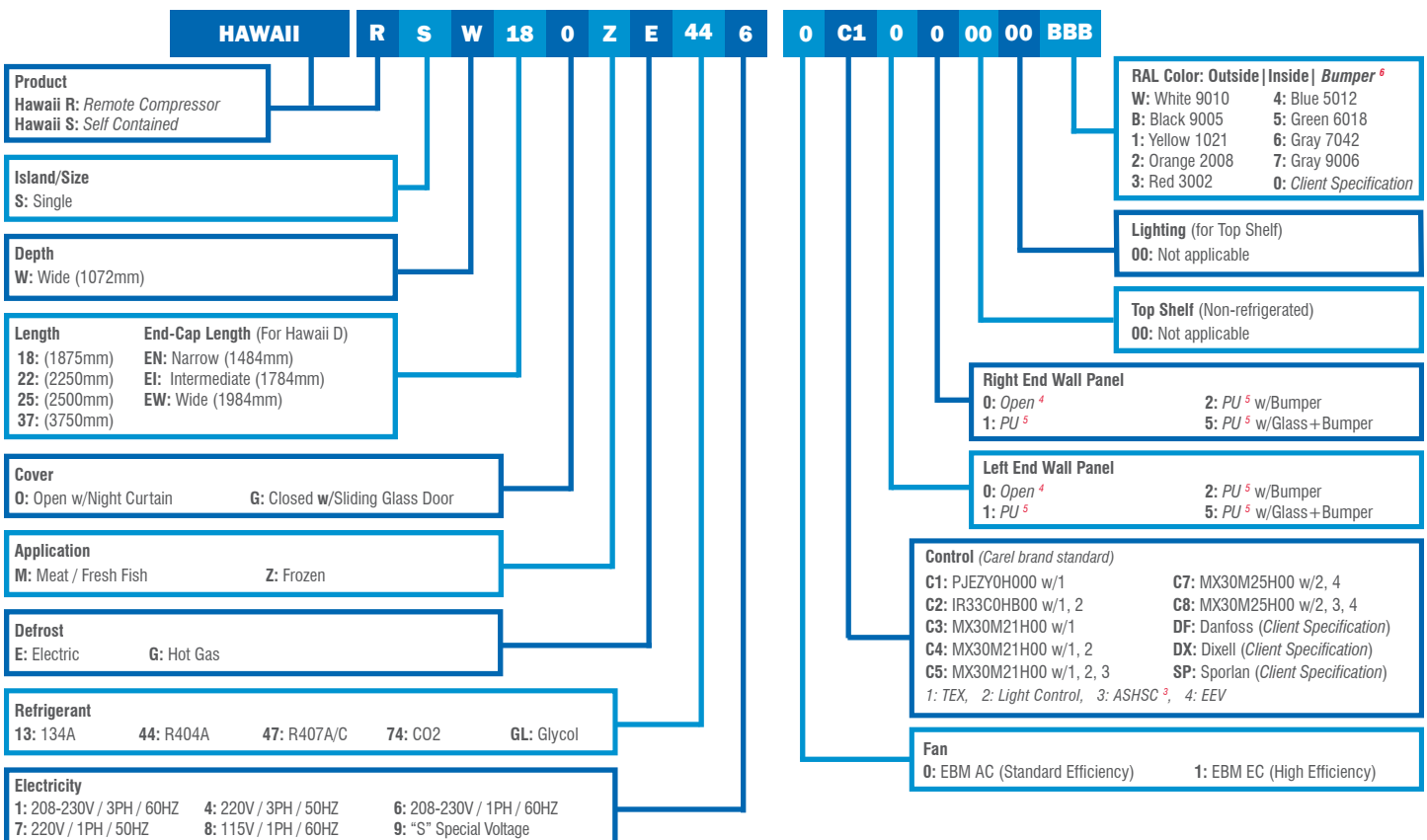

<sup>3</sup> ASHSC "Anti-Sweat Heater Smart Control"

<sup>5</sup> PU "Polyurethane"

<sup>4</sup> Open when joining cases.

<sup>6</sup> Bumper only available in B & 6



**CORPORATE OFFICE:** 4362 Thurmon Tanner Parkway / Flowery Branch, GA 30542 / USA

Tel.: +1-678-714-6991 / Fax: +1-678-714-2357 / Toll Free: 1-855-374-2660

Venezuela: (0251) 710 5067 / Colombia: (1) 381 9070 / Mexico: (55) 4161 3805

Dominican Republic: (829) 954 8425 / Peru: (1) 705 6209 / info@friconusa.com / www.friconusa.com